

OPS1000 two-way optical station

Description

The forward receiver adopt the high performance active photoelectric transform module with ORTEL technology, the RF amplifier adopt the GaAs power multiplier gain module; and the reverse transmitter adopt the high quality FP laser, the output power is 0~3dbm. In addition, the cost of this product reduced by adopting the latest applied technique of the photoelectric products. This product becomes much suitable for the HFC network after times of improvement. The feed as well as the output form are able to satisfy the requirement of different users.

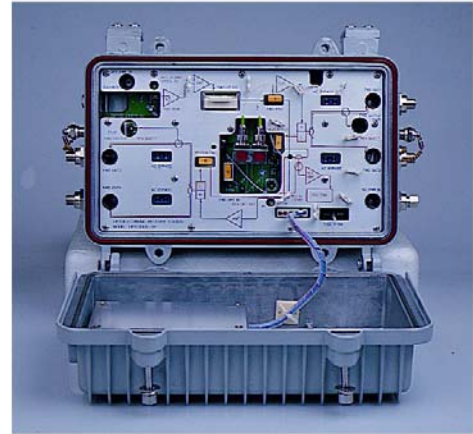

Feature

- The forward receiver adopt the high performance active photoelectric transform module with ORTEL technology, and the reverse transmitter adopt the high quality FP laser
- The GaAs power multiplier gain module improves the performance of RF amplifier.
- When OPS1000 has dual channel output, each output level will reach 110 dB μ V (pin=1dB, 9dB tilt output at 85~862MHz), when OPS1000 has quad channel output, each output level will reach 106 dB μ V.
- When OPS1000 has single channel output, each output level will reach 110 dB μ V (pin=1dB, 9dB tilt output at 85~862MHz), when OPS1000 has quad channel output, each output level will reach 102 dB μ V.
- The reverse optical module, the reverse optical amplifier module and the duplex filter module are able to be updated on-line.
- Input optical power test point at 0.2mw/v; LED alarm for optical signal loss, easy to test optical circuit operation.
- Optical connection with waterproof; many forms of ways to connect fibers
- Aluminum alloy cast shell, housing with good waterproof, operating outdoor condition.

Product identification system

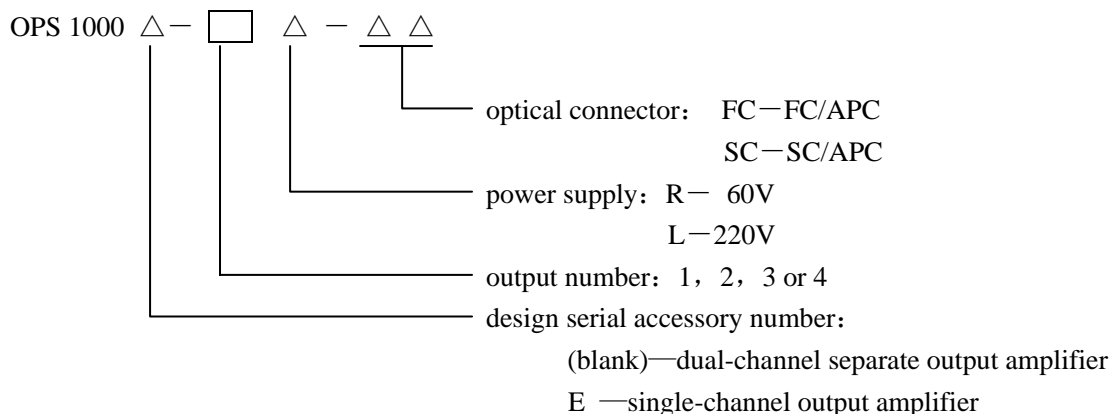

Specifications

Item	Note	OPS1000	OPS1000E	Unit
Forward path				
Optical characteristics				
Optical fiber		9/125/900	9/125/900	μ m
Optical receiver wavelength		1100~1600	1100~1600	nm
Optical return loss		>40	>40	dB
Optical power range		+3 ~ -7	+3 ~ -7	dBm
Optical connector		SC/APC or FC/APC	SC/APC or FC/APC	
Input optical power test point		0.2	0.2	mW/V
RF output				
Frequency range		47~750/862	47~750/862	MHz
flatness		$\pm 0.75(47\sim 862\text{MHz})$	$\pm 0.75(47\sim$	dB
Return loss		16@550MHz, 14@862MHz	16@550MHz, 14@8	dB
Output port number	1	≤ 4 channels	≤ 4 channels	
Output impedance		75	75	Ω
Output level	2,5	46~50	42~50	dBmV
Test port		-20	-20	dB
Link performance				
C/N	2,3,4	51	51	dB
CSO	2,3,4	-62	-62	dBc
CTB	2,3,4	-66	-66	dBc
Reverse path				
optical characteristics				
Type of laser		Fabry-Perot	Fabry-Perot	
Optical wavelength		1310 \pm 20	1310 \pm 20	nm
Output optical power		0 to 3	0 to 3	dBm
Fiber connector		SC/APC or FC/APC	SC/APC or FC/APC	
Output optical power test point		1	1	mW/V
RF input				

Frequency range	5~200	5~200	MHz
Slope	0 to -1	0 to -1	dB
Flatness	±0.5	±0.5	dB
Return loss(75ohms)	16	16	dB
RF input test point	- 20	- 20	dB
RF driver level (from 5 to 65MHz)	-34	-34	dBmV/Hz
Link performance			
C/N (link loss 6dB)	45	45	dB
Combination distortion component	-60	-60	dBc
Power supply			
AC operating voltage	40~90	40~90	V
Operation environmental temperature	- 25 ~ + 55	- 25 ~ + 55	°C

- Note
- 1: Output channels (from 2 to 4) optional
 - 2: Optical receiver input power -1dBm.
 - 3: PAL-D/K 59 channels Chinese standard.
 - 4: Refer to OT7C&OT8C or TXA optical transmitter performance table.
 - 5: 4 channels output, 9dB slope condition, OPS1000E each output 42dBmV, OPS1000 each output 46dBmV.